

Backdraft Damper

PR50

Aluminum Blades • 200°F Max. Temperature • Vertical or Horizontal Mount

STANDARD CONSTRUCTION

- FRAME:** 20-GA galvanized rolled frame
- BLADE:** .35" aluminum blades
- AXLE PINS:** Zinc plated with push on retainer clips
- STOP ANGLES:** 20-GA galvanized
- BLADE STIFFENER:** 20-GA galvanized
- SEALS:** Self adhesive .125" x .375" foam
- FINISH:** Mill

NOTES

1. Damper frames are provided approximately 1/4" undersized.
2. Dampers are for vertical mount, horizontal airflow; horizontal mount, vertical up or down airflow.

DESIGN CRITERIA

- MAX VELOCITY:** 1000 fpm
- MAX DIFF PRESSURE:** 1 in.wg
- MAX TEMPERATURE:** 200°F

DAMPER SIZE

Panels	Min Panel	Max Panel
Drop-In Frame	5" dia.	24" dia.
Size Chart		
Size	Actual Frame Diameter	Frame Depth
5"	4.87"	7.5"
6"	5.87"	7.5"
7"	6.87"	7.5"
8"	7.87"	7.5"
9"	8.87"	7.5"
10"	9.87"	7.5"
11"	10.87"	7.5"
12"	11.87"	10.5"
13"	12.87"	10.5"
14"	13.87"	10.5"
15"	14.87"	10.5"
16"	15.87"	10.5"
17"	16.87"	12.5"
18"	17.87"	12.5"
19"	18.87"	12.5"
20"	19.87"	12.5"
21"	20.87"	12.5"
22"	21.87"	12.5"
23"	22.87"	12.5"
24"	23.87"	12.5"

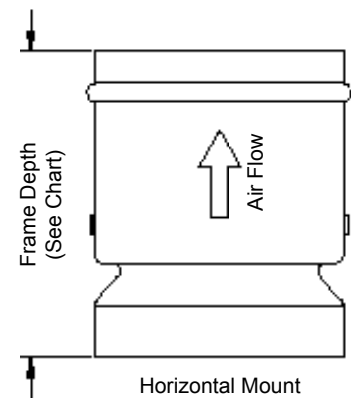
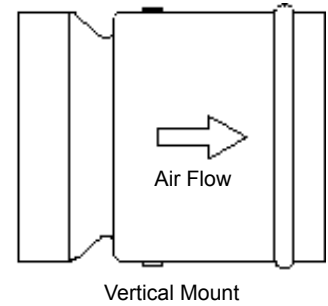
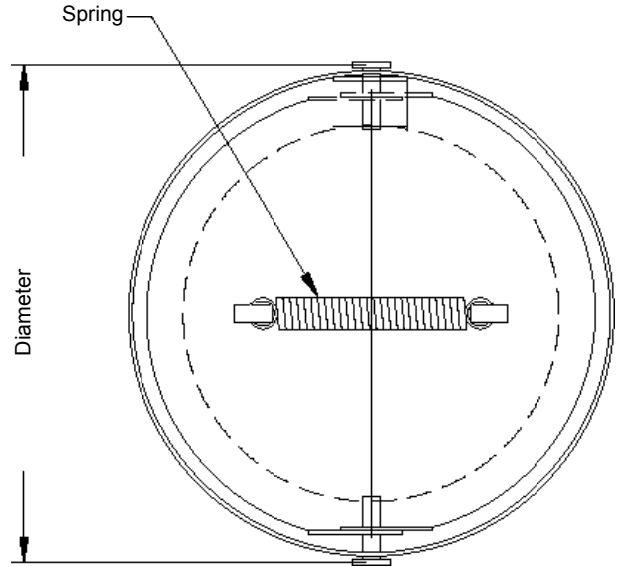

This page intentionally left blank.